



## **SCHOOL DISTRICT OF LANCASTER**

**Bid # 3727**  
**for**  
**Cafeteria Equipment**

**For the period commencing July 1, 2026 through and including June 30, 2027**

Issued on May 12, 2026

**Pre-Bid Conference:**

There will be no pre-bid conference for this solicitation.

**Proposal Submittal Deadline:**

Friday, June 2, 2026 at 2:00 PM EST

**Proposal Opening Date, Time, and Location:**

Friday, June 2, 2026 at 2:30 PM EST

Location TBD – Pre-registration required

## **Section 1. INVITATION**

The School District of Lancaster will receive sealed bids for Cafeteria Equipment, according to the specifications contained in this document.

Bid documents can be obtained from the District's website, <https://sdlancaster.org/grow/bids-proposals>.

Modifications, additions, or changes to the terms and conditions of this bid may be cause for rejection of a proposal. Vendors are requested to submit all attached forms in the format provided.

[END OF SECTION]

**Section 2. TABLE OF CONTENTS**

Section 1. Invitation .....2

Section 2. Table of Contents .....3

Section 3. Contacts and Response Information.....4

    3.1 Proposal Questions and Registration:.....4

    3.2 Submission of Proposals: .....4

    3.3 Response Documentation:.....4

    3.4 Bid Timeline:.....4

Section 4. General Terms & Conditions .....5

Section 5. Bid Requirements .....6

Section 6. Product Specifications .....10

ATTACHMENT A. FORM OF PROPOSAL.....11

ATTACHMENT B. NON-COLLUSION AFFIDAVIT .....12

ATTACHMENT C. ADDENDUM ACKNOWLEDGEMENT FORM .....13

ATTACHMENT D. MINORITY BUSINESS ENTERPRISE TYPE.....14

APPENDIX TO FOLLOW LAST PAGE

## Section 3. CONTACTS AND RESPONSE INFORMATION

### 3.1 Proposal Questions and Registration:

Questions regarding this Bid should be directed to Renee Ortiz, Business & Operations Specialist, at [rortiz@sdlancaster.org](mailto:rortiz@sdlancaster.org) and received no later than 2:00 PM EST, May 26, 2026. Responses to questions will be provided on May 28, 2026, via an addendum published to the [District's website](#). All questions must be submitted in writing; verbal inquiries will not be honored.

### 3.2 Submission of Proposals:

Bids are due on June 2, 2026, no later than 2:00 PM EST. Bids must be submitted in a sealed envelope, clearly labeled "Bid 3727: Cafeteria Equipment" on the outside. Each bid package should include the following:

- One printed copy of all required forms and documentation

Should an event cause The District to close, we will accept proposals until 2:00 PM EST on the next operating day. Should you deliver or have a company deliver your submission, the proposal shall be sealed in an envelope/package clearly marked with the title of the bid, the due date and time, and delivered to:

School District of Lancaster  
Attn: Renee Ortiz  
1020 Lehigh Ave  
Lancaster, PA 17602

If necessary, addenda to this bid will be posted to the District's website (<https://sdlancaster.org/grow/bids-proposals/>). The District will make every effort to notify registered proposers when an addendum is posted; however, it is recommended that proposers check the District's website for all posted addenda prior to final submission. All proposers must confirm receipt of the addenda by returning Attachment C, if the addenda has been issued.

Proposers, by their submission of a proposal, agree to conduct legally binding transactions by electronic means, within the meaning of the "Electronic Transactions Act," 73 P.S. 2260.101 et seq. ("ETA"). Electronic documents and records and electronic signatures shall be the equivalent of written documents and records and written signatures, pursuant to ETA. Neither the School District of Lancaster nor any of the participants make any representation or warranty concerning the reliability or security of any communication links, networks, or any data or information transmitted electronically, and neither the School District of Lancaster nor any of the participants shall be liable or responsible, in any manner, for any failure, interruption or breach of any communication link, network, or security measure.

### 3.3 Response Documentation:

The following documentation must be received for a completed bid submission. Failure to receive these completed documents on or before the stated deadline may result in the rejection of the electronic bid response. The documents are available for access through the District's website.

- Form of Proposal (Attachment A)
- Non-Collusion Affidavit (notarization required) (Attachment B)
- Addendum Acknowledgement Form (if applicable) (Attachment C)
- Minority Business Enterprise Type (Attachment D)
- Pricing Sheet (Appendix A)

### 3.4 Bid Timeline:

**Deadline for Written Inquiries:** May 26, 2026 at 2:00 PM EST

**Response to Questions:** May 28, 2026 by 5:00 PM EST

**Proposal Submittal Deadline:** June 2, 2026 at 2:00 PM EST

**Anticipated Board Approval:** June 16, 2026

[END OF SECTION]

#### **Section 4. GENERAL TERMS & CONDITIONS**

1. Ensure that your proposal complies with all requirements specified in this bid. Attention to all clauses of these requirements is advised.
2. Complete all documents by printing neatly and legibly in pen or typing. Electronic documents must also be completed by typing into the appropriate spaces. Do not alter, delete or change any bid specifications or clauses in the bid documents.
3. Indicate prices for every item you are bidding on.
4. Any variation in your proposal from the conditions and specifications as outlined in this bid must be clearly stated, with the variation from specifications noted.
5. No bidder may withdraw his/her bid for a period of ninety (90) days after the date set for the opening thereof.
6. No rights shall accrue to any person submitting a proposal until such proposal has been accepted, contract awarded, and such contract finally and completely executed in writing.
7. The District is Tax-Exempt and a certificate will be provided to the successful proposer upon request.

[END OF SECTION]

## Section 5. BID REQUIREMENTS

1. **Purpose:** The purpose of this bid proposal is to solicit prices to:
  - a. Furnish and install cafeteria equipment at various locations
2. **Make/Model:**
  - a. Designer Line Roll-In Refrigerator, Model No. D2RIN-E or equivalent
  - b. Convotherm Combi Steamer, Model No. C4eT 10.20 GB or equivalent
  - c. ServIt Four Pan Open Well Electric Steam Table, Model No. 423EST4W5KS or equivalent
  - d. Galaxy Commercial Chest Freezer - 9.6 cu. ft., Model No. 177CF10HC or equivalent
  - e. MainStreet Holding Cabinet, Model No. CH-1836U or equivalent
3. **Documentation:** Bidder must provide details or specification sheets on the models provided in their respective bid proposal. If an equivalent model is proposed, the bidder must provide a written statement indicating the differences between the models listed above and the proposed equivalent models. The bidder must submit a statement guaranteeing that the equivalent model can be installed and will operate in the same fashion as the model listed above.
4. **Additional Work:** Installation of equipment. Preparation of the site for hook-up of gas and electrical as necessary. If additional work, such as electrical or plumbing, etc., is necessary, the bidder is responsible for including this work in their labor fees. All work is required to meet federal, state and local building codes.
5. **Labor:** Bid proposal is to include details for the equipment as follows:
  - a. Install and set up of equipment in the proper location
  - b. Electrical and gas hook-up and installation, as necessary
  - c. Any additional work (e.g. electrical, plumbing) that may be required to complete the installation
6. **Warranty:** Bid proposal is to provide warranty details as well as options for extended warranties.
7. **Deposits:** A Security Deposit or Bid Bond is not required for this bid.
8. **Conformity to Product Specifications:** The successful bidder agrees that in the event that the District has accepted and paid for a shipment of a specified item(s), but shall discover upon opening at a later date that the item(s) does not conform to specifications and/or other quality standards of the sample(s) herewith, the bidder shall promptly remove such rejected items, at the District's request and at the bidder's expense, and the bidder agrees to replace promptly any or all of the quantity rejected with products that meet specifications and/or conform to standards of the sample(s) without extra charge to the District.
9. **Insurance Requirements:** Contractor (and any subcontractor) shall obtain and maintain insurance as follows, unless waived in writing by the District:
  - a. **Automobile Liability:** Automobile Liability Insurance covering all owned, hired and non-owned vehicles in the amount of \$1,000,000 per occurrence with not more than \$1,000 per occurrence deductible or self-insurance retention.
  - b. **Workers Compensation:** Workers Compensation Insurance, disability benefit and other social insurance as may be required by law.
  - c. **Comprehensive General Liability:** Comprehensive General Liability insurance in the amount of \$1,000,000 per occurrence with not more than \$1,000 per occurrence deductible or self-insurance retention.
  - d. **Excess (Umbrella) Liability:** Excess Liability coverage of \$1,000,000, unless waived by District.
    - i. Except for Workers Compensation Insurance, District shall be named as certificate holder and a primary, non-contributory additional insured under such insurance coverage.
    - ii. Contractor shall submit insurance certificates ("Certificates") to School District evidencing required insurance coverage at the time of submission of this Agreement and at any other time(s) upon School District's reasonable request(s). Certificates evidencing the required insurance shall stipulate that School District shall receive thirty (30) days prior written notice of any change or cancellation in

coverage. If Contractor or any subcontractor fails to carry any insurance required by this Section, Contractor shall protect, indemnify and hold harmless School District in the same manner as if Contractor and/or such subcontractor had in full force and effect coverage in accordance with this Section.

- iii. Contractor shall comply with, and shall cause all subcontractors to comply with, all conditions of each insurance contract and all requirements of this Section.
10. **Indemnification:** In addition to the insurance requirements included as part of the specifications, the contractor shall also defend, indemnify and hold harmless the School District of Lancaster and its Boards of School Directors from and against any and all claims, suits judgments, and demands whatsoever, including without limitation to costs, litigation expenses, counsel fees, and liabilities with respect to injury to, or death of, any person or persons whatsoever, or damage to property of any kind by whosoever owned, arising out of or caused or claimed to have been caused in whole or in part by the acts or omissions of the contractor, its agents or employees, in the performance of the contract and further agrees to indemnify the District against any such claims allegedly caused in whole or in part, whether or not it be the fact, by reason or negligent instructions or directions given or purportedly given by any of the District representatives with respect to the performance of the contract.
11. **Termination:** The District may terminate or cancel any awarded contract(s) at any time, with or without cause, by providing seven (7) days advance written notice to the awarded vendor(s). If the awarded contract(s) is terminated in accordance with this paragraph, the awarded vendor(s) shall only be entitled to payment for goods or services delivered prior to the termination and not otherwise returned in accordance with the return policy of the awarded vendor(s). If the awarded vendor(s) was paid for goods not yet provided as of the date of termination, the awarded vendor(s) shall immediately refund such payment(s). If the District terminates any awarded contract(s) in accordance with this paragraph, the District shall retain all rights and remedies allowed by law.
12. **Default/Recourse:** In the event the successful Contractor fails or refuses to perform the work or services required, or any part thereof as provided in these specifications or to replace any which are rejected, then the Board of School Directors is authorized to immediately contract for the work or services in conformity with the contract from such party or parties in such quantities and in such manner as it shall select at the expense of the successful Contractor, or to immediately cancel the contract, reserving to itself nevertheless all rights for damages which may be incurred by the School District.
13. **Buy American:** The Warren F. Goodling Child Nutrition Reauthorization Act of 1998, as may be amended, requires sponsors of the National School Lunch Program to buy domestic commodities or products for use in meals to the maximum extent possible. Specification of product origin, based on the Nutrition Labeling and Education Act of 1990, as may be amended, mandates that the country of origin for both domestic and imported food products be identified on the product label. Products bid MUST comply with the foregoing regulations and all applicable federal, state and local laws and regulations.
14. **Small and Minority Businesses, Women’s Business Enterprises, and Labor Surplus Area Firms:** The awarded vendor(s) shall comply with the requirements of 2 C.F.R. § 200.321, addressing contracting with small and minority businesses, women’s business enterprises, and labor surplus area firms. To that end, the awarded vendor(s) shall (i) place qualified small and minority businesses and women’s business enterprises on solicitation lists; (ii) assure that small and minority businesses, and women’s business enterprises are solicited whenever they are potential sources; (iii) divide total requirements, when economically feasible, into smaller tasks or quantities to permit maximum participation by small and minority businesses, and women’s business enterprises; (iv) establish delivery schedules, where the requirement permits, which encourage participation by small and minority businesses, and women’s business enterprises; (v) use the services and assistance, as appropriate, of such organizations as the Small Business Administration and the Minority Business Development Agency of the Department of Commerce; and (vi) require that, if subcontracts are to be let, to take the affirmative steps listed in paragraphs (i) through (v) of this Section 28.
15. **Debarment and Suspension:** Debarment and Suspension (Executive Orders 12549 and 12689). A contract award (see 2 CFR 180.220) must not be made to parties listed on the government-wide exclusions in the System for Award Management (“SAM”), in accordance with the Office of Management and Budget, more commonly known as “OMB,” guidelines at 2 CFR 180 that implement Executive Orders 12549 (3 CFR Part 1966 Comp. p. 189) and 12689 (3 CFR Part 1989 Comp. p. 235), “Debarment and Suspension.” SAM exclusions contain the names of parties debarred, suspended, or otherwise excluded by agencies, as well as parties declared ineligible under statutory or regulatory authority other than Executive Order 12549. Bidder certifies that bidder is not currently listed on the government-wide exclusions in SAM, is not debarred, suspended, or otherwise excluded by agencies or declared ineligible under statutory or regulatory authority other than Executive Order 12549. Awarded vendor(s) further agrees to immediately notify the District with

pending purchases or seeking to purchase from awarded vendor(s) if awarded vendor(s) is later listed on the government-wide exclusions in SAM, or is debarred, suspended, or otherwise excluded by agencies or declared ineligible under statutory or regulatory authority other than Executive Order 12549.

16. **Byrd Anti-Lobbying Amendment:** Byrd Anti-Lobbying Amendment (31 USC 1352). Vendors that apply or bid for an award exceeding \$100,000 must file the required certification. Each tier certifies to the tier above that it will not and has not used federal appropriated funds to pay any person or organization for influencing or attempting to influence an officer or employee of any agency, a member of Congress, officer or employee of Congress, or an employee of a member of Congress in connection with obtaining any federal contract, grant or any other award covered by 31 USC 1352. Each tier must also disclose any lobbying with non-federal funds that takes place in connection with obtaining any federal award. Such disclosures are forwarded from tier to tier up to the non-federal award. As applicable, all bidders and awarded vendor(s) agree to file all certifications and disclosures required by, and otherwise comply with, the Byrd Anti-Lobbying Amendment (31 USC 1352).
17. **Right to Inventions Made Under a Contract or Agreement:** If District's federal award meets the definition of "funding agreement" under 37 CFR 401.2(a) and the recipient or subrecipient wishes to enter into a contract with a small business firm or nonprofit organization regarding the substitution of parties, assignment or performance or experimental, developmental, or research work under that "funding agreement," the recipient or subrecipient must comply with the requirements of 37 CFR Part 401, "Rights to Inventions Made by Nonprofit Organizations and Small Business Firms Under Government Grants, Contracts and Cooperative Agreements," and any implementing regulations issued by the awarding agency. The awarded vendor(s) agrees to comply with the above requirements when applicable.
18. **Standard Contract Conditions**
  - a. The contract shall be governed in all respects as to validity, the construction, capacity, performance, or otherwise by the laws of the Commonwealth of Pennsylvania. Exclusive venue and jurisdiction for resolution of any disputes shall be by non-jury trial in the Lancaster County, Pennsylvania, Court of Common Pleas.
  - b. Awarded Vendors providing services under a contract herewith assure District that they conform to the provisions of the Civil Rights Act of 1964, as amended.
  - c. District is tax-exempt. State Sales and Use Tax Certificate of Exemption form will be issued upon request.
  - d. Deliveries under the contract must be free of excise or transportation fees and taxes, except when such a fee or tax is included in the bid price and participants are not exempt from such levies.
  - e. The awarded vendor shall comply with all applicable federal, state and local laws and regulations pertaining to wages, hours and conditions of employment. In connection with awarded vendor's performance of work under the contract, awarded vendor agrees not to discriminate against any employee(s) or applicant(s) for employment because of age, race, religious creed, sex, national origin, or handicap. Additionally, all applicable federal, state and local laws and regulations shall be deemed to be part of the contract and specifications, and the awarded vendor shall be responsible for compliance therewith.
  - f. Product Protection Guarantees. School districts have "automatic" product protection recourse against suppliers for product safety. According to federal regulations, the supplier whose name and address appear on the package is the responsible party. Awarded vendors are expected to take immediate action to correct any situation in which product integrity is violated.
  - g. Coupons. The awarded vendor(s) shall ensure all applicable coupons and rebate opportunities are made available to the CAFCO participants during the course of the contract term.
19. **Equal employment Opportunity:** Except as otherwise provided under 41 CFR Part 60, all CAFCO purchases or contracts that meet the definition of "federally assisted construction contract" in 41 CFR Part 60-1.3 shall be deemed to include the equal opportunity clause provided under 41 CFR 60-1.4(b), in accordance with Executive Order 11246, "Equal Employment Opportunity" (30 FR 12319, 12935, 3 CFR Part, 1964-1965 Comp.,p. 339), as amended by Executive Order 11375, "Amending Executive Order 11246 Relating to Equal Employment Opportunity," and implementing regulations at 41 CFR Part 60, "Office of Federal Contract Compliance Programs, Equal Employment Opportunity, Department of Labor." The equal opportunity clause provided under 41 CFR 60-1.4(b) is hereby incorporated by reference. The awarded vendor(s) agrees that such provision applies to any CAFCO purchase or contract that meets the definition of "federally assisted construction contract" in 41 CFR Part 60-1.3 and the awarded vendor(s) agrees that it shall comply with such provision.
20. **Assignment:** The awarded vendor shall not assign the performance of the contract nor any portion thereof to any other person without written consent from the District.

[END OF SECTION]

**Section 6. PRODUCT SPECIFICATIONS**

Description	Quantity	Price
<p><b>2-Section Extra-High Roll-In Refrigerator:</b> Commercial roll-in refrigerator, two-section, extra-high design to accommodate 72" carts; stainless steel interior and exterior; self-contained refrigeration system; digital controls; automatic defrost; LED lighting; NSF/ANSI 7 and UL listed; R-290 refrigerant; 115V, single phase; includes ramps and door locks. Continental Refrigerator Model D2RIN-E or approved equivalent. Pricing must be provided as a delivered cost, inclusive of all freight charges. Delivery will be made to a standard loading dock, no liftgate required.</p>	3	
<p><b>Combi Steamer:</b> Commercial combi oven/steamer with easyTouch controls; capable of steaming, convection cooking, and combination modes; stainless steel construction; programmable touchscreen interface; automatic cleaning system; includes core temperature probe; NSF and UL listed; electric operation, 120V, 1PH, 60Hz; suitable for high-volume foodservice applications. Convotherm Model Convotherm 4 easyTouch or approved equal. Pricing must be provided as a delivered cost, inclusive of all freight charges. Delivery will be made to a standard loading dock, no liftgate required.</p>	1	
<p><b>Four-Pan Open Well Electric Steam Table:</b> Commercial electric steam table with four open wells; includes angled sneeze guard, fixed tray slide, and heavy-duty casters; stainless steel construction; individual thermostatic controls for each well; 120V; NSF and UL listed. ServIt Model #423EST4W5KS or approved equal. Pricing must be provided as a delivered cost, inclusive of all freight charges. Delivery will be made to a standard loading dock, no liftgate required.</p>	Dry 1	
<p><b>Commercial Chest Freezer:</b> Commercial-grade chest freezer with approximately 9.6 cubic feet capacity; stainless steel or heavy-duty painted steel exterior; corrosion-resistant interior liner; manual defrost; locking lid with key; adjustable temperature control; NSF and UL listed; uses environmentally friendly refrigerant (R-290 or equivalent); includes basket(s) for product organization. Galaxy Model CF10HC or approved equal. Pricing must be provided as a delivered cost, inclusive of all freight charges. Delivery will be made to a standard loading dock, no liftgate required.</p>	6	
<p><b>Holding Cabinet:</b> Full size uninsulated holding cabinet holds up to 36 full size sheet pans; 1 1/2" of clearance between slides; adjustable temperature settings up to 185 degrees Fahrenheit; clear door; 120V, 1,630W; MainStreet Model CH-0836U or approved equal. Pricing must be provided as a delivered cost, inclusive of all freight charges. Delivery will be made to a standard loading dock, no liftgate required.</p>	2	

[END OF SECTION]

**ATTACHMENT A. FORM OF PROPOSAL**

To: School District of Lancaster  
Attn: Business Office  
251 S. Prince Street, 3<sup>rd</sup> Floor  
Lancaster, PA 17603

We, the undersigned, herewith propose and agree to furnish to the participants any item or items at the quoted price.

This proposal is subject to all the terms of the Request for Proposals/Bid, including all sections and attachments, and any revisions, clarifications, error correction notices, and explanatory notes issued via addendum prior to proposal opening, and we hereby agree to enter into a written contract to furnish such item(s), as may be awarded to us.

We understand that the School District of Lancaster reserves the right to reject any or all proposals or any portion thereof not deemed satisfactory, or to select single items from any bids.

The undersigned certifies to having read the Request for Proposal/Bid, including all sections and attachments, and any revisions, clarifications, error correction notices, and explanatory notes issued via addendum prior to bid opening and offers to furnish supplies and/or materials as specified to the District in exact accordance with these specifications and conditions at the prices stated on the attached forms and/or electronic proposal submission.

Date: \_\_\_\_\_

Name of Company: \_\_\_\_\_

Name & Title of authorized Bidder (printed):

\_\_\_\_\_

Address: \_\_\_\_\_

\_\_\_\_\_

Telephone: \_\_\_\_\_

Fax: \_\_\_\_\_

Email: \_\_\_\_\_

Authorized Signature: \_\_\_\_\_

**ATTACHMENT B. NON-COLLUSION AFFIDAVIT**

Bid/RFP Number: \_\_\_\_\_

State of: \_\_\_\_\_

County of: \_\_\_\_\_

I state that I am \_\_\_\_\_ (title) of \_\_\_\_\_ (Name of Firm) and that I am authorized to make this affidavit on behalf of my firm, and its owners, directors, and officers. I am the person responsible in my firm for the price(s) and the amount of this bid.

I state that:

1. The price(s) and amount of this bid have been arrived at independently and without consultation, communication or agreement with any other contractor, bidder or potential bidder.
2. Neither the price(s) nor the amount of this bid, and neither the approximate price(s) nor approximate amount of this bid, have been disclosed to any other firm or person who is a bidder or potential bidder, and they will not be disclosed before bid opening.
3. No attempt has been made or will be made to induce any firm or person to refrain from bidding on this contract, or to submit a bid higher than this bid, or to submit any intentionally high or noncompetitive bid or other form of complementary bid.
4. The bid of my firm is made in good faith and not pursuant to any agreement or discussion with, or inducement from, any firm or person to submit a complementary or other noncompetitive bid.
5. \_\_\_\_\_ (Name of Firm), its affiliates, subsidiaries, officers, directors and employees are not currently under investigation by any governmental agency and have not in the last three years been convicted or found liable for any act prohibited by State or Federal law in any jurisdiction, involving conspiracy or collusion with respect to bidding on any public contract, except as follows:

I state that \_\_\_\_\_ (Name of Firm) understands and acknowledges that the above representations are material and important, and will be relied on by School District of Lancaster in awarding the contract(s) for which this bid is submitted. I understand and my firm understands that any misstatement in this affidavit is and shall be treated as fraudulent concealment from School District of Lancaster of the true facts relating to the submission of bids for this contract.

Signature: \_\_\_\_\_

Name and Title: \_\_\_\_\_

SWORN TO AND SUBSCRIBED BEFORE ME

THIS \_\_\_\_ DAY OF \_\_\_\_\_, 20 \_\_\_\_

\_\_\_\_\_  
Notary Public

My Commission Expires: \_\_\_\_\_

**ATTACHMENT C.      ADDENDUM ACKNOWLEDGEMENT FORM**

Indicate below your confirmation of all addendums received for the above aforementioned bid. This document will become part of the bid documents and will need to be submitted with the balance of bid documentation.

We hereby confirm receipt of all addendums indicated below in response to Bid 3727: Cafeteria Equipment

ADDENDUM #1

Date\_\_\_\_\_

Signature\_\_\_\_\_

ADDENDUM #2

Date\_\_\_\_\_

Signature\_\_\_\_\_

ADDENDUM #3

Date\_\_\_\_\_

Signature\_\_\_\_\_

**ATTACHMENT D. MINORITY BUSINESS ENTERPRISE TYPE**

Indicate below if your organization is considered a minority business enterprise (MBE), as classified in Federal 2 C.F. R. 200.321. Additionally, indicate the MBE status of any suppliers or subcontractors which may be utilized in this proposal. This document will become part of the bid documents and will need to be submitted with the balance of bid documentation.

Vendor Name: \_\_\_\_\_

- Minority-Owned
- Women-Owned
- Small Business
- Section 8A
- Disabled Veteran
- HUB
- Not Applicable

Supplier or Subcontractor \_\_\_\_\_

- Minority-Owned
- Women-Owned
- Small Business
- Section 8A
- Disabled Veteran
- HUB
- Not Applicable

Supplier or Subcontractor \_\_\_\_\_

- Minority-Owned
- Women-Owned
- Small Business
- Section 8A
- Disabled Veteran
- HUB
- Not Applicable

Date \_\_\_\_\_

Signature \_\_\_\_\_

# DESIGNER LINE ROLL-IN REFRIGERATOR

## Model: D2RIN-E

Natural Refrigerant R-290 Model



## 2-Section Extra-High Roll-In Refrigerator with 72" Cart Capacity

- D2RIN-E** - Stainless steel front, aluminum end panels and interior
- D2RINSA-E** - Stainless steel exterior, aluminum interior
- D2RINSS-E** - Stainless steel exterior and interior



## Options and Accessories

(upcharge and lead times may apply)

Epoxy coated steel shelves	Special electrical req. (consult factory)
Chrome or stainless steel shelves	<b>Correctional Facility Options</b>
Rehinging of doors (consult factory)	<ul style="list-style-type: none"> <li>• One way security screws</li> </ul>
Custom laminates	<ul style="list-style-type: none"> <li>• Locking hasp (lock not included)</li> </ul>
Half doors	<ul style="list-style-type: none"> <li>• Stainless steel mesh cover</li> </ul>
Stainless steel back	<ul style="list-style-type: none"> <li>• Coverless hinges</li> </ul>

Consult factory for other model configurations, options and accessories.



Project Name:

Model Specified:

Location:

Item No:

Quantity:

AIA #:

SIS #:

## Standard Model Features

### REFRIGERATION SYSTEM

Self contained, performance rated "plug" refrigeration system

Natural, environmentally safe, high efficiency R-290 refrigerant<sup>1</sup>

Refrigeration system is readily accessible on top of cabinet, separate from the "food zone"

Automatic, hot gas condensate evaporator

Expansion valve system

### CABINET ARCHITECTURE

3" non-CFC polyurethane foam insulation

Smooth, polished chrome workflow door handles

Cam action, lift off hinges

Magnetic snap in Santoprene™ door gaskets

Cylinder lock in each door

Self-closing doors

72 1/2" high door opening (72"H rack capacity\*)

### MODEL FEATURES

Electronic control, off cycle defrost

LED interior lighting

Top and side air distribution ducts

Cabinet upper side panels and refrigeration "plug" system can be removed and reinstalled at job site

Removable stainless steel rack guides

Removable stainless steel ramps

Reinforced stainless steel floor

\* Rack not supplied

**IMPORTANT NOTE:** <sup>1</sup> R-290 refrigerant meets all federal and state regulatory requirements.

APPROVAL:

# Model Specifications

## DIMENSIONAL DATA

Net Capacity (cubic feet)	68 (1926 cu l)
Width, Overall (inches)	68 1/2 (1740 mm)
Depth, Overall (inches) (including handles)	35 3/8 (899 mm)
Depth (inches) (less doors)	32 (813 mm)
Depth (inches) (doors open 90°)	65 (1651 mm)
Clear Door Width (inches)	27 3/8 (695 mm)
Clear Full Door Height (inches)	72 1/2 (1842 mm)
Height, Overall (inches)	92 (2337 mm)
Number of Door(s)	2
Rack Capacity**	2

## REFRIGERANT DATA

Condensing Unit Size (H.P.)	1/2+
Capacity (BTU per hour)*	4010

\* Rating @ +25°F evaporator, 90°F ambient

## ELECTRICAL DATA

Voltage (International)	115/60/1 (220/50/1)
Feed Wires (including ground)	3
Total Amps (International)	9.4 (4.2)
10 ft. Cord/Plug [attached] (International)	Yes (No)

## SHIPPING DATA

Height - Crated (inches)	97 (2464 mm)
Width - Crated (inches)	77 (1956 mm)
Depth - Crated (inches)	42 (1067 mm)
Volume - Crated (cubic feet)	176 (4984 cu l)
Weight Std - Crated (pounds)	730 (331 kg)
Weight SS - Crated (pounds)	890 (404 kg)

\* Rating @ +25°F evaporator, 90°F ambient

\*\* Maximum rack size including wheels - 27"W x 29"D x 72"H

Figures in parentheses reflect metric equivalents rounded to the nearest whole unit.



Equipped with one NEMA-5-15P Plug  
(varies by country)

# Model Plan Views

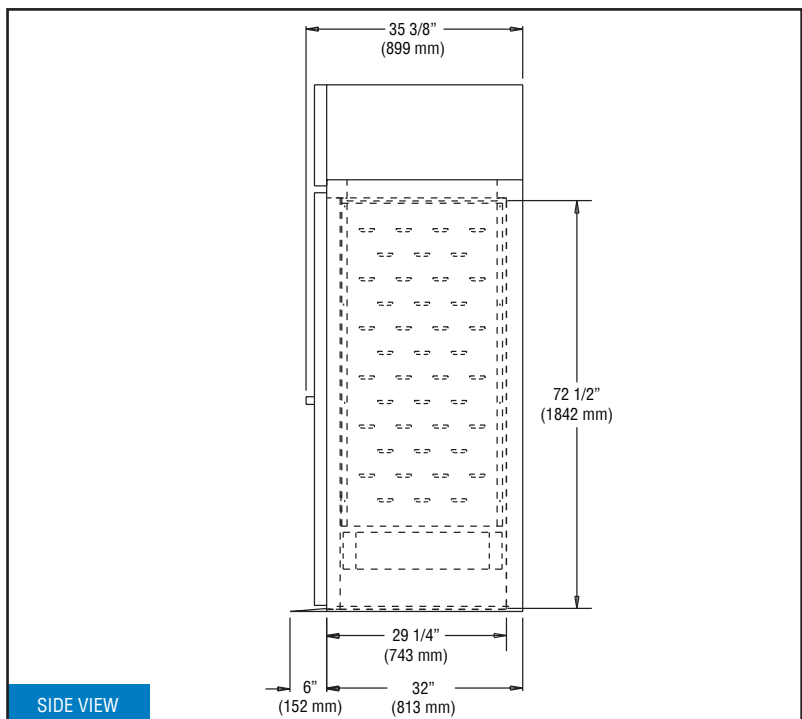
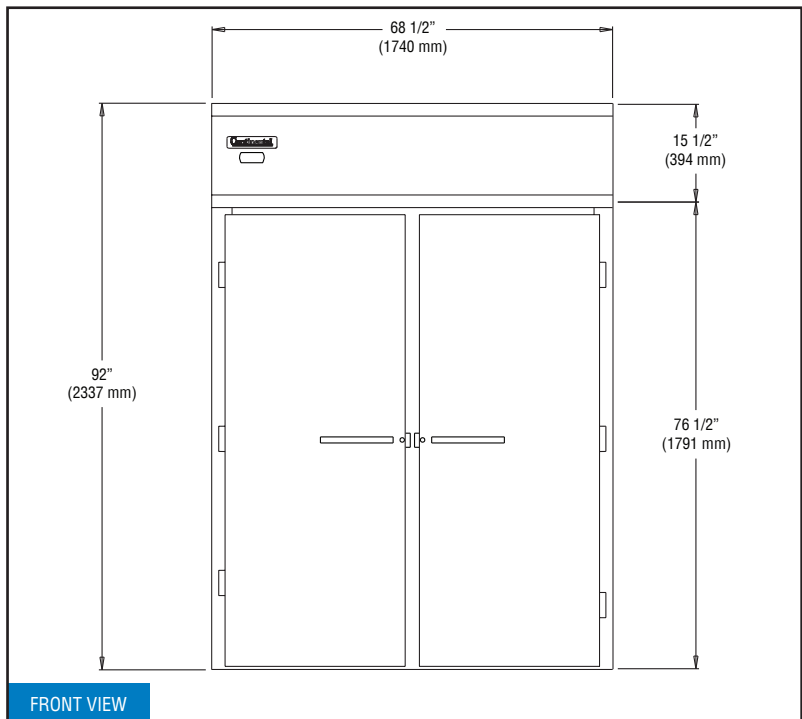

**IMPORTANT NOTE:** If the cabinet is located directly against a wall and/or under a low ceiling, a minimum clearance of 12" is required on top and 3" on sides and rear.



Toll-Free: 800-523-7138  
Phone: 215-244-1400  
Fax: 215-244-9579

539 Dunksferry Road  
Bensalem, PA 19020  
[www.continentalrefrigerator.com](http://www.continentalrefrigerator.com)

Due to our continued efforts in developing innovative products, specifications subject to change without notice.



PROUDLY  
DESIGNED & ASSEMBLED  
IN THE U.S.A.

© Copyright 2021. Continental Refrigerator.  
A Division of National Refrigeration & Air Conditioning Products, Inc.

REVISED: 5/04/2024

# Combi steamer

Project \_\_\_\_\_

Item \_\_\_\_\_

Quantity \_\_\_\_\_

FCSI section \_\_\_\_\_

Approval \_\_\_\_\_

Date \_\_\_\_\_

C4eT 10.20 GB

## Model

Convotherm 4 easyTouch

- easyTouch
- 11 Shelves
- Gas
- Boiler
- Right-hinged door



## Key features

- ACS+ operating modes: Steam, combi-steam, hot air
- ACS+ extra functions:
  - Crisp&Tasty - 5 moisture-removal settings
  - BakePro - 5 levels of traditional baking
  - HumidityPro - 5 humidity settings
  - Controllable fan - 5 speed settings
- easyTouch 9" full-touch screen
- ConvoClean+ fully automatic cleaning system with eco, regular and express modes - with optional single-dose dispensing
- Ethernet interface (LAN)
- HygienicCare
- USB port integrated in the control panel
- TriColor indicator ring - indicates the current operating status
- Steam generated by high-performance boiler outside the cooking chamber
- Right-hinged door

## Standard features

- ACS+ (Advanced Closed System +) operating modes:
  - Steam (86-266°F) with guaranteed steam saturation
  - Combi-steam (86-482°F) with automatic humidity adjustment
  - Hot air (86-482°F) with optimized heat transfer
- HygienicCare - food safety provided by antibacterial surfaces:
  - easyTouch control panel
  - Door handle and recoil hand shower
- easyTouch user interface:
  - 9" full-touch screen
  - Press&Go - automatic cooking with quick-select buttons
  - TrayTimer - oven-load management for different products at the same time
  - Regenerate+ - flexible multi-mode retherm function
  - ecoCooking - energy-save function
  - Low-temperature cooking / Delta-T cooking
  - Cook&Hold - cook and hold in one process
  - 399 cooking profiles each containing up to 20 steps
  - On-screen help with topic-based video function
  - Start-time preset
- Multi-point core temperature probe
- Door handle with safety latch and slam function
- Data storage for HACCP and pasteurization figures
- Preheat and cool down function

## Options

- Steam and vapor removal - built-in condenser
- Disappearing door - more space and added safety (see separate data sheet)
- Grill version with grease management
- Available in various voltages
- Sous-vide probe, external connection
- Core temperature probe, external connection

## Accessories

- ConvoLink HACCP and cooking-profile management PC software
- Signal tower - indicates the operating status from a distance
- Banquet system (optionally as a package or individually): Plate rack, mobile shelf rack, transport trolley, thermal cover
- Equipment stands in various sizes and designs
- Racks for cooking and baking
- Cleaning products for the fully automatic ConvoClean+ cleaning system and the semi-automatic cleaning system

**Front view**

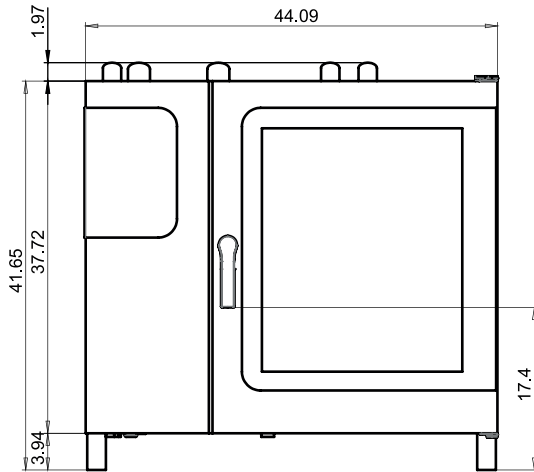

**Connection positions**

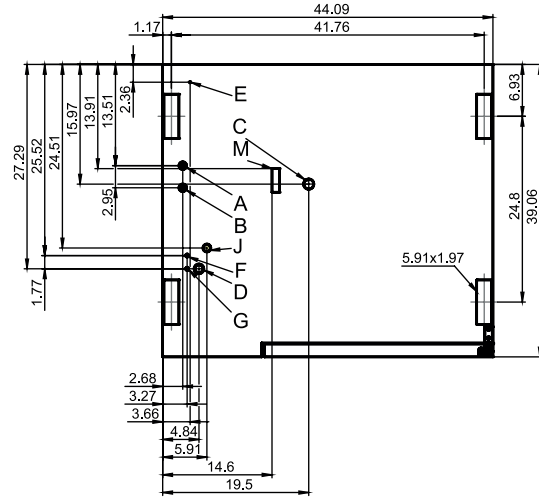

**View from above with wall clearances**

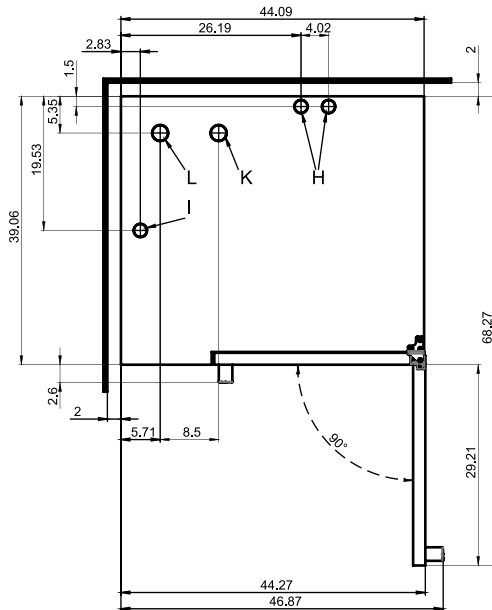

- A** Water connections (for boiler)
- B** Water connections (for cleaning, recoil hand shower)
- C** Drain connection (2" I. D.)
- D** Electrical connection
- E** Electrical ground
- F** Rinse-aid connection
- G** Cleaning-agent connection
- H** Air vent (2" I. D.)
- I** Ventilation port
- J** Gas connection
- K** Exhaust outlet (cooking compartment heating element)
- M** Safety overflow 3.2" x 1"

**Dimensions and weights**

**Dimensions including packaging**

Width x Height x Depth 53" x 50.4" x 44.9"

**Weight**

Net weight without options\* / accessories 492 lbs

Packaging weight 77 lbs

**Safety clearances\*\***

Rear 2"

Right 2"

Left (18" clearance recommended for service) 2"

Top\*\*\* 39"

\*Max. weight of options 22 lbs.

\*\*Minimum clearance from heat sources: 20".

\*\*\*Depends on the type of exhaust system and the ceiling's characteristics.

**Installation requirements**

**Inclination**

Max. absolute appliance inclination during operation\* max. 2° (3.4%)

\*Adjustable appliance feet as standard.

### Loading capacity

**Max. number of food containers**

[Unit has 11 shelves, shelf spacing 2.68" max.]

Steam table pans (12"x20"x1")	20
Steam table pans (12"x20"x2.5")	20
Full size wire racks (20"x26")	10
Full size sheet pans (18"x26")	10
Half size sheet pans (13"x18")	20
Frying baskets (12"x20")	20
Plates (optional plate rack)	48

**Max. loading weight**

Per combi steamer	220 lbs
Per shelf	33 lbs

### Electrical supply

**120V 1PH 60Hz \***

Rated power consumption	0.6 kW
Rated current	6.1 A
Power supply wire gauge	14 AWG
Conductor insulation rating	194°F

\*Prepared for connection to an energy optimizing system.

### Water connections

**Water supply**

Water supply	Two 3/4" I. D. GHT-M (garden hose adapter). The appliance is designed for a permanent hookup to the water supply that uses a connecting hose with a minimum diameter of 1/2"
Flow pressure	22 - 87 PSI / 1.5 - 6 bar

**Drain**

Drain version	Permanent hookup (recommended) or funnel waste trap
Type	2" I. D. (comes elbow-shaped as standard)
Slope for drainpipe	min. 5% (3°)

### Water quality

**Water connection A\* for boiler, Water connection B\* for cleaning, recoil hand shower**

General requirements	Drinking water, typically untreated water
TDS	70 - 360 ppm
Hardness	70 - 360 ppm (4 - 21 gpg)
pH value	6.5 - 8.5
Cl <sup>-</sup> (chloride)	max. 60 ppm
Cl <sub>2</sub> (free chlorine)	max. 0.2 ppm
SO <sub>4</sub> <sup>2-</sup> (sulfate)	max. 150 ppm
Fe (iron)	max. 0.1 ppm
SiO <sub>2</sub> (silica)	max. 13 ppm
NH <sub>2</sub> Cl (monochloramine)	max. 0.2 ppm
Temperature	max. 104 °F

\*See connection positions diagram, p. 2.

NOTICE: The owner/operator/purchaser must ensure that the water quality requirements are met. Otherwise the original equipment warranty is void.

**Emissions**

<b>Heat emission</b>	
Latent	6730 BTU/h
Sensitive	6824 BTU/h
<b>Drain temperature</b>	max. 140°F / 60°C
<b>Decibel rating</b>	max. 70 dBA

**Water consumption**

<b>Water connections A, B</b>	
Average consumption for cooking**	2.32 gph
Required flow rate	3.96 gpm

\*\*Incl. water required for cooling the wastewater.

NOTICE: See connection positions diagram, p. 2.

**Gas specifications**

Type of gas	Natural gas, propane
Gas connection	3/4" NPT
<b>Flow pressure</b>	
Natural gas	5.5 - 14" WC
Propane	11 - 14" WC
<b>Heat output</b>	
For Natural gas, propane	
Convection burner	109200 BTU/h
Boiler burner	102000 BTU/h

**Please note:**

- Please refer to the Installation manual for further technical data and for instructions on installation and setup.
- Convotherm reserves the right of design improvement or modification, as warranted.
- There are numerous federal, national and local laws, regulations and standards. It is the responsibility of the owner and installer to observe these laws, regulations and standards (e.g. fire regulations and health and safety standards).
- Convotherm combi steamers are built to comply with the applicable standards for manufacturers.

9758251\_01 ENG\_USA 10/14. © 2014 Manitowoc. Please note that the product is being continuously improved and that, as a result, these specifications are subject to change without notice.



## ServIt Four Pan Open Well Electric Steam Table with Angled Sneeze Guard, Fixed Tray Slide, and Casters - 120V, 2000W

#423EST4W5KS

### FEATURES

- Durable 20-gauge type 304 stainless steel wells
- 6" deep wells hold 4 full size food pans (sold separately); accommodates various pan configurations
- Convenient adjustable undershelf provides additional space to store utensils, pans, lids, or serving
- Removable 8" deep cutting board provides plenty of extra work space
- Fixed tray slide provides a place to rest plates while serving; mounting hardware included
- only the table holds the ETL certification

### TECHNICAL DATA

Width	57 3/8 Inches
Depth	30 5/8 Inches
Height	34 3/8 Inches
Power Cord Length	7 1/4 Feet
Sneeze Guard Length	57 5/8 Inches
Tray Length	57 3/8 Inches
Compatible Pan Depth	6 Inches
Cutting Board Depth	8 Inches
Sneeze Guard Depth	15 Inches
Tray Depth	12 1/2 Inches



### CERTIFICATIONS



ETL Sanitation



ETL, US & Canada



5-30P

## TECHNICAL DATA

Sneeze Guard Height	15 Inches
Tray Height	8 Inches
Phase	1 Phase
Voltage	120 Volts
Wattage	2000 Watts
Assembly Options	Assembly Required
Base Style	Undershelf
Brakes	With Brakes
Casters	With Casters
Color	Silver
Control Type	Infinite
Cutting Board Thickness	1/2 Inch
Features	Cutting Board Mobile Plate Tray Undershelf With Sneeze Guard
Installation Type	Floor Model
Material	Stainless Steel
Number of Pans	4 Pans
Number of Wells	4
Plug Type	NEMA 5-30P
Power Type	Electric
Style	Floor Model
Type	Mobile
Usage	Indoor
Well Type	Open / Dry Well

# Notes & Details

---

Keep all of your menu items piping hot and readily available with this ServIt four pan open well electric steam table with angled sneeze guard, fixed tray slide, and casters! This kit includes (1) four pan open well electric steam table, (1) angled sneeze guard, (1) fixed tray slide, and (4) casters with brakes. The steam table can hold four full size food pans (sold separately) full of pasta, meat, or side dishes in each 500W well. Each individual well is independently controlled by an infinite control knob with detailed lighting showing whether the unit is powered on and if the well is ready to use. The body of this unit is constructed of durable 22-gauge type 430 stainless steel and heavy-duty hardware. The top and wells are made of 20-gauge type 304 stainless steel, while the cutting board support shelves are made of 16-gauge type 430 stainless steel.

The steam table includes an adjustable undershelf to store extra serving utensils, food pans, or lids to keep all the tools you need close at hand. For extra convenience, the 1/2" thick polyethylene cutting board is 8" deep and gives you an extra workspace for changing out food pans or filling plates. The sneeze guard enhances safety, as the acrylic shield design creates a barrier between your food and the people viewing and serving it. This reduces the chances of spreading foodborne illness. The sneeze guard features an angled design that's perfect for one-sided service. The fixed tray slide attaches to the table and gives customers a solid area to place their plates while they are served. Mounting hardware is included.

The included casters allow for mobility and smooth, convenient transportation, so you can move your table around your event without spilling any of your dishes. They also include brakes that ensure that the table can stay secure and stationary when required. With a 5" diameter, the casters also raise the table by 6", which can help lift the work area to a more comfortable, ergonomic height. Use this steam table kit for a safe, efficient way to serve food at your catered event or buffet! A 120V electrical connection is required for the 7 1/4' power cord.

## **Kit Includes:**

- (1) Four pan steam table
- (1) Angled sneeze guard
- (1) Fixed tray slide
- (4) Casters with brakes

**⚠ WARNING:** This product can expose you to chemicals including lead, which are known to the State of California to cause cancer and birth defects or other reproductive harm. For more information, go to [www.p65warnings.ca.gov](http://www.p65warnings.ca.gov).

Project \_\_\_\_\_

Item 177CF10HC \_\_\_\_\_ Quantity \_\_\_\_\_

Approval \_\_\_\_\_ Date \_\_\_\_\_

# Galaxy CF10HC Commercial Chest Freezer - 9.6 cu. ft.

Item #177CF10HC

## Special Features

- Durable aluminum interior, painted steel exterior; 9.6 cu. ft. of interior storage space with lock
- Foamed in place polyurethane insulation helps maintain performance even in 90 degree ambient
- Includes 1 epoxy-coated steel basket with a weight capacity of 33 lb.
- Designed for commercial use to provide reliability, durability, and ease of use
- 1/5 hp; uses R600a refrigerant

## Technical Data

<b>Width</b>	40 5/8 Inches
<b>Depth</b>	29 3/4 Inches
<b>Height</b>	33 Inches
<b>Power Cord Length</b>	6 Feet
<b>Interior Width</b>	34 5/8 Inches
<b>Interior Depth</b>	20 5/8 Inches
<b>Interior Height</b>	25 1/2 Inches
<b>Amps</b>	1.02 Amps
<b>Hertz</b>	60 Hz
<b>Voltage</b>	115 Volts



## Certifications

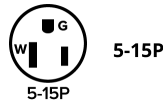

## Technical Data

<b>Wattage</b>	172.5 Watts
<b>Capacity</b>	9.6 cu. ft.
<b>Door Style</b>	Swing
<b>Door Type</b>	Solid
<b>Horsepower</b>	1/5 hp
<b>Number of Doors</b>	1 Doors
<b>Plug Type</b>	NEMA 5-15P
<b>Refrigerant Type</b>	R-600a
<b>Temperature Range</b>	-8 - 0 Degrees F

 **WARNING:** This product can expose you to chemicals including Lead, which are known to the State of California to cause cancer and birth defects or other reproductive harm. For more information, go to [www.p65warnings.ca.gov](http://www.p65warnings.ca.gov).



Project \_\_\_\_\_

Item 541CH1836U Quantity \_\_\_\_\_

Approval \_\_\_\_\_ Date \_\_\_\_\_

# MainStreet Equipment CH-1836U Full Size Non-Insulated Heated Holding Cabinet with Clear Door - 120V

Item #541CH1836U

## Special Features

- Full size uninsulated design holds up to 36 full size sheet pans; 1 1/2" of clearance between slides
- Full heat mode with 9 adjustable temperature settings up to 185 degrees Fahrenheit
- Lexan clear door with magnets and tight-fitting gasket
- Integrated easy-to-read LED display on removable bottom control drawer
- 120V, 1,630W

## Technical Data

<b>Width</b>	22 11/16 Inches
<b>Depth</b>	32 3/4 Inches
<b>Height</b>	66 7/16 Inches
<b>Power Cord Length</b>	102 3/8 Inches
<b>Interior Width</b>	18 3/16 Inches
<b>Interior Depth</b>	27 1/8 Inches
<b>Interior Height</b>	53 13/16 Inches
<b>Hertz</b>	60 Hz
<b>Phase</b>	1 Phase
<b>Voltage</b>	120 Volts



## Certifications



NSF Certified



5-15P



UL Certified

## Technical Data

<b>Wattage</b>	1630 Watts
<b>18" x 26" Pan Capacity</b>	36 Pans
<b>Access Type</b>	Doors
<b>Cabinet Size</b>	Full Height
<b>Casters</b>	With Casters
<b>Control Location</b>	Bottom Mounted
<b>Control Type</b>	Analog
<b>Door Type</b>	Clear
<b>Dutch Half Doors</b>	Without Dutch Half Doors
<b>Features</b>	NSF Certified
<b>Installation Type</b>	Freestanding
<b>Insulated</b>	Without Insulation
<b>Interior Configuration</b>	Lip Load Slides
<b>Lip Load Capacity</b>	100 lb.
<b>Maximum Temperature</b>	185 Degrees F
<b>Number of Doors</b>	1 Doors
<b>Plug Type</b>	NEMA 5-15P
<b>Power Type</b>	Electric
<b>Sections</b>	1 Section
<b>Type</b>	Holding Cabinets

## Technical Drawing

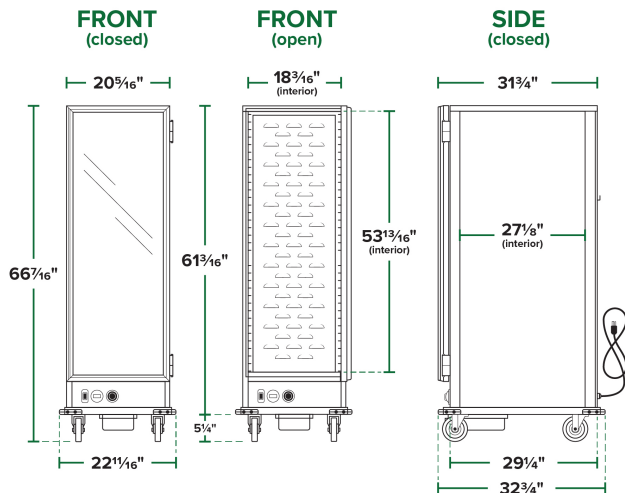

**⚠ WARNING:** This product can expose you to chemicals including lead, which are known to the State of California to cause cancer and birth defects or other reproductive harm. For more information, go to [www.p65warnings.ca.gov](http://www.p65warnings.ca.gov).